

Legend describe

1. Color to be determined;
2. Louver drive motor 220V, 1 built-in motor;
3. The size of rain-proof shutter is 3000mm * 3000mm * 2500mm;
4. Three LED leaf lights and LED light strips around are equipped;

Project name:

Sheet Name:

Technical signature:

Column layout plan

Drawing scale:

Drawing No:

Customer signature:

PM-01

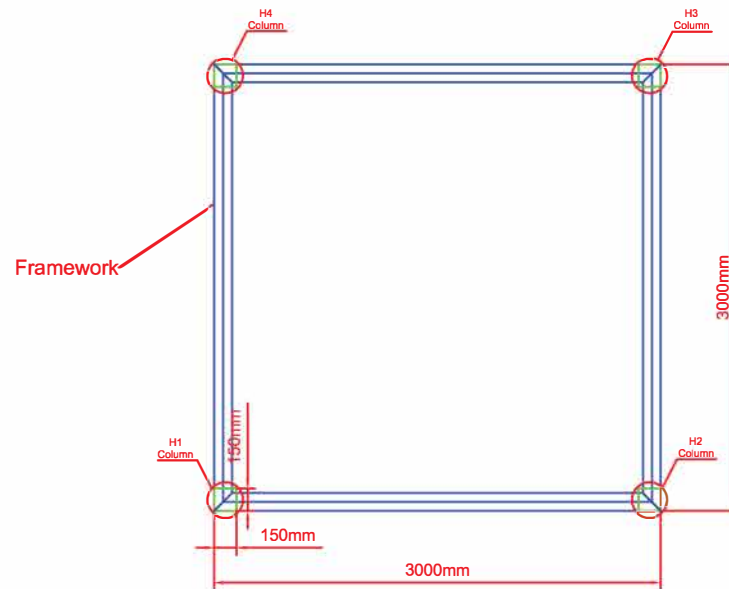

Legend describe

1. Color to be determined;
2. Louver drive motor 220V, 1 built-in motor;
3. The size of rain-proof shutter is 3000mm * 3000mm * 2500mm;
4. Three LED leaf lights and LED light strips around are equipped;

Project name:

Sheet Name:

Technical signature:

Frame layout plan

Drawing scale:

Drawing No:

Customer signature:

PM-02

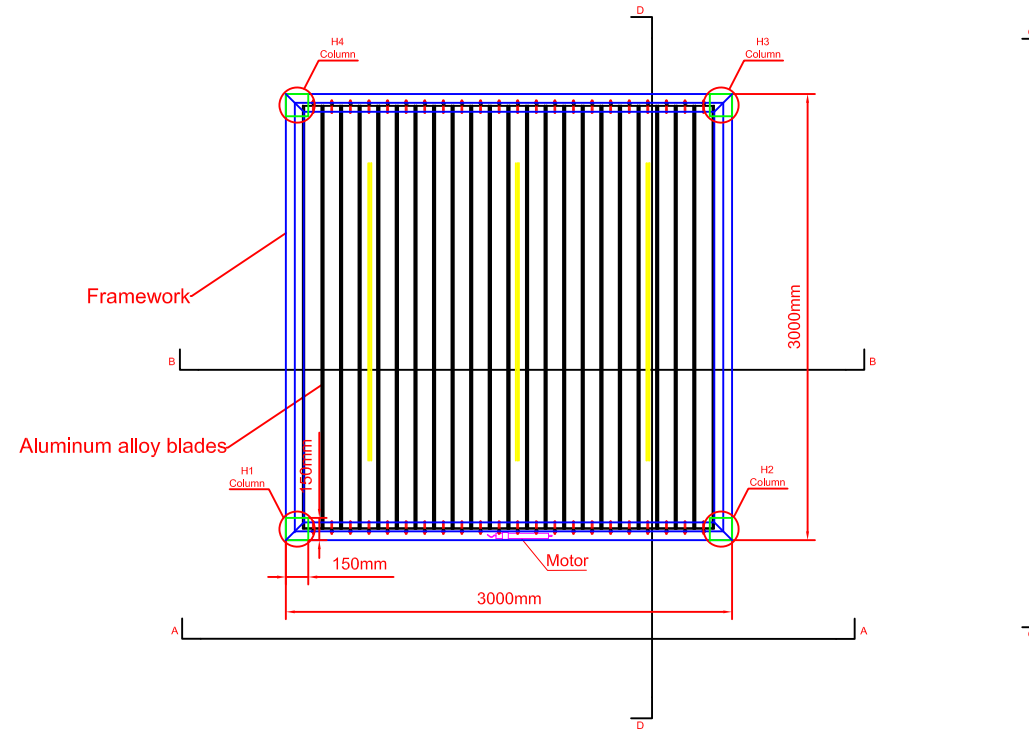

Legend describe

1. Color to be determined;
2. Louver drive motor 220V, 1 built-in motor;
3. The size of rain-proof shutter is 3000mm * 3000mm * 2500mm;
4. Three LED leaf lights and LED light strips around are equipped;

Project name:

Sheet Name:

Technical signature:

Louver Layout Plan

Drawing scale:

Drawing No:

Customer signature:

PM-03

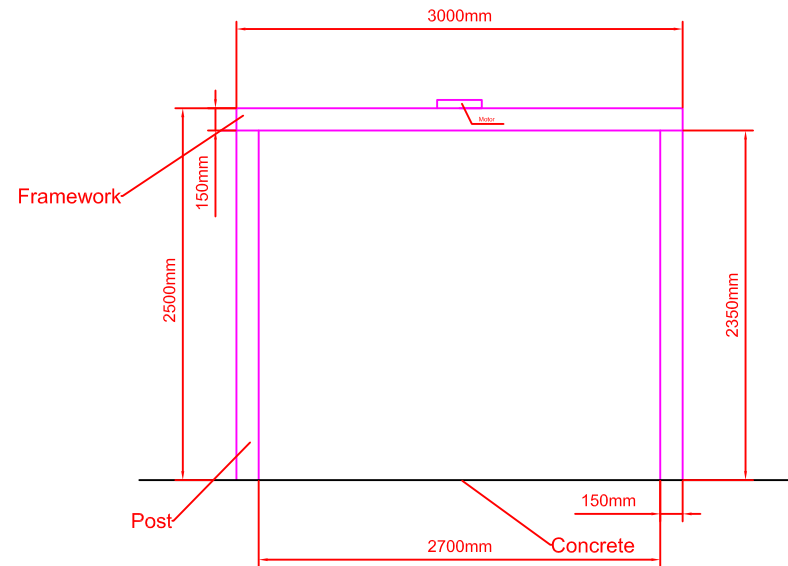

**Legend
describe**

1. Color to be determined;
2. Louver drive motor 220V, 1 built-in motor;
3. The size of rain-proof shutter is 3000mm * 3000mm * 2500mm;
4. Three LED leaf lights and LED light strips around are equipped;

Project name:

Sheet Name:

A-A Cutaway view

Technical signature:

Drawing scale:

Drawing No:

PM-04

Customer signature:

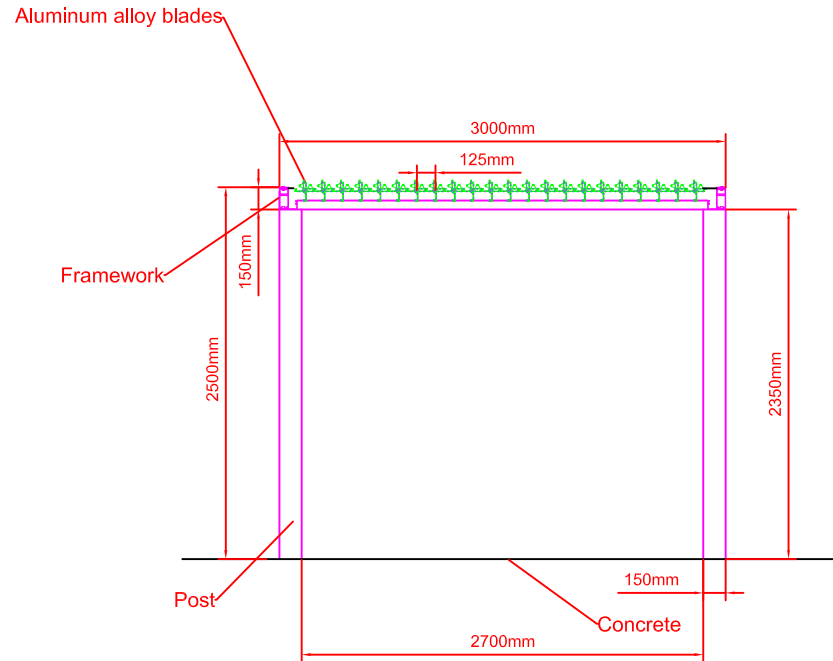

Legend describe

1. Color to be determined;
2. Louver drive motor 220V, 1 built-in motor;
3. The size of rain-proof shutter is 3000mm * 3000mm * 2500mm;
4. Three LED leaf lights and LED light strips around are equipped;

Project name:

Sheet Name:

B-B Cutaway view

Technical signature:

Drawing scale:

Drawing No:

PM-05

Customer signature:

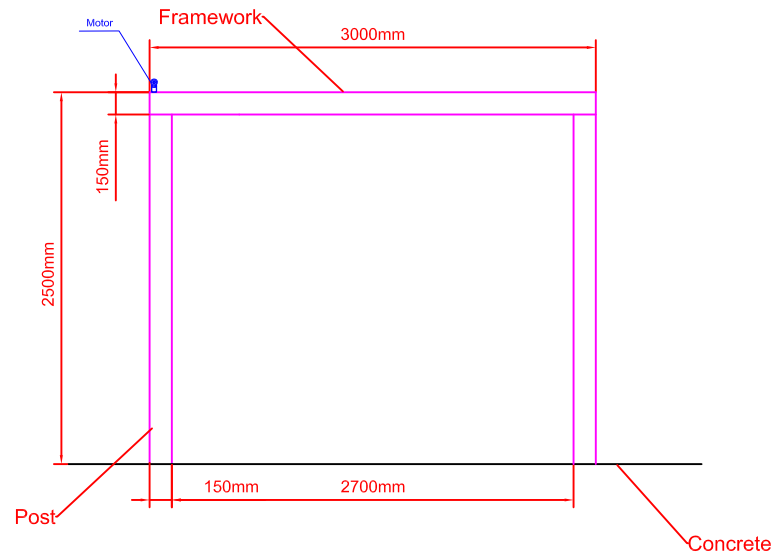

**Legend
describe**

1. Color to be determined;
2. Louver drive motor 220V, 1 built-in motor;
3. The size of rain-proof shutter is 3000mm * 3000mm * 2500mm;
4. Three LED leaf lights and LED light strips around are equipped;

Project name:

Sheet Name:

C-C Cutaway view

Technical signature:

Drawing scale:

Drawing No:

PM-06

Customer signature:

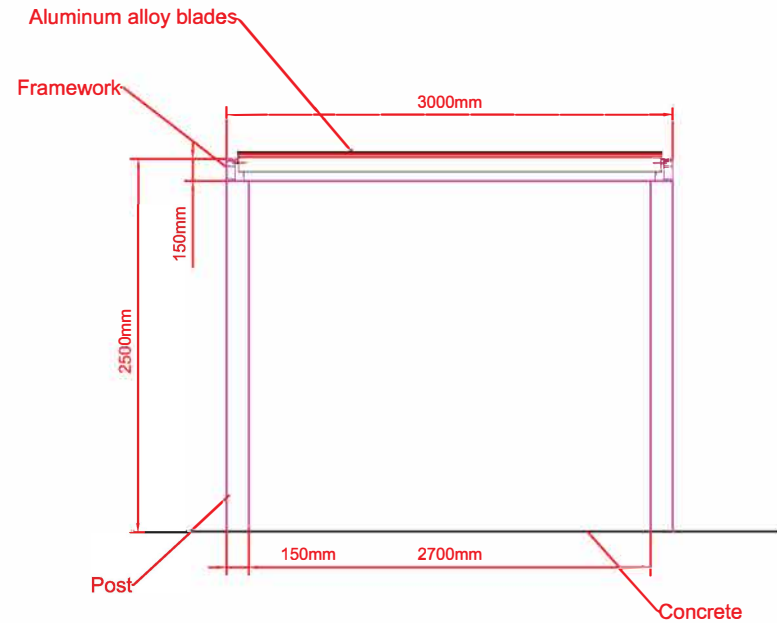

**Legend
describe**

1. Color to be determined;
2. Louver drive motor 220V, 1 built-in motor;
3. The size of rain-proof shutter is 3000mm * 3000mm * 2500mm;
4. Three LED leaf lights and LED light strips around are equipped;

Project name:

Sheet Name:

Technical signature:

D-D Cutaway view

Drawing scale:

Drawing No:

Customer signature:

PM-07